



## SQ.V0.G38 Valve Series

**GAS Cartridge – 420 Bar**  
**Direct acting – In line sequence valve**  
**Steel housing**

### Description & Operation

Direct acting in-line sequence valve with steel housing. The SQV combines in one easy-to-install in line valve the typical function of shock relief valve, side-in nose-exhaust. In the pressure relief function it provides very low pressure rise thanks to the smart deflector design. When the pressure at the high pressure inlet (2) reaches the valve setting, the valve starts to open to tank (1). The pressure rise is very low thanks to the smart deflector design. Flow passage in the opposite direction (1 to 2) is blocked. High precision machining guarantees quick response to load changes, limited hysteresis and reduced

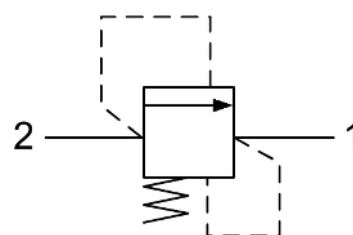
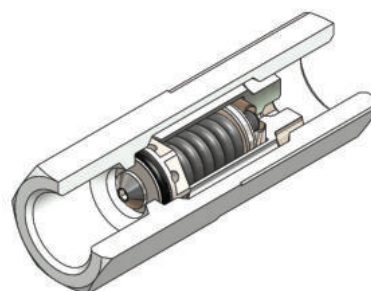

Hydraulic Symbol

### Technical Data

Maximum operating pressure	420 Bar
Maximum flow	60 LPM
Maximum internal leakage	1 cm <sup>3</sup> / min to 80% of nominal set point
Pressure setting established	@ 10.00 LPM
Reset pressure	90% of cracking pressure
External component treatment	Zn/Fe - standard (96h) Zn/Ni (720h) upon customer request
O-ring Temperature Range	-30° C to 110° C (standard sealing NBR - BUNA-N)
Oil Temperature Range	-30° C to 110° C
Fluids	Mineral - based or synthetics with lubricating properties
Viscosities	7.4 to 420 cSt
Filtration	20/18/15 ISO 4406 (maximum filtration admitted)
Orientation	No restrictions
Oil testing condition	ISO VG 46 cSt
Weight	0.148 Kg

 **Dimensional Drawing**

**Cross Section and Cavity Details**

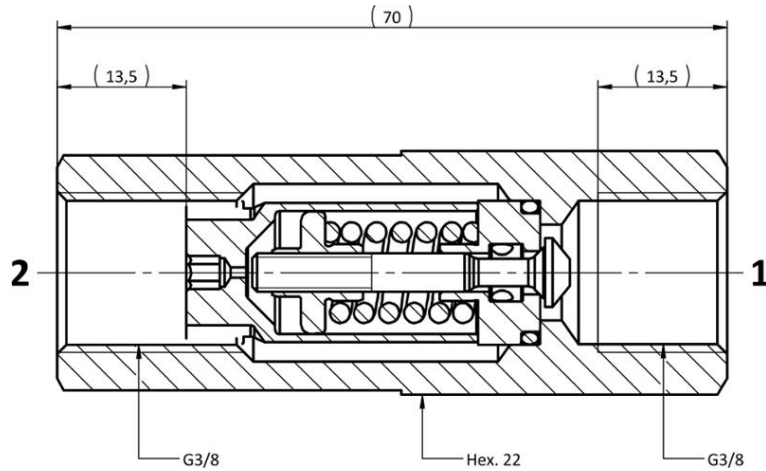

 **Ordering Code**

S Q • V 0 • G 3 8 • 0 \* • \* \* \*

valve basic code

**Cavity**  
G38 = GAS 3/8

**Marking**  
0 = standard factory marking. customized marking can be done upon request

**Pressure setting in (bar)**  
Note = Standard setting are multiple of 5 bars.

**Spring range**

Model Code	Pressure setting range (Bar)
N	20-70
B	71-130
G	131-210
V	211-280
W	281-350
R	351-420

 **Performance Curve**

- Spring = N

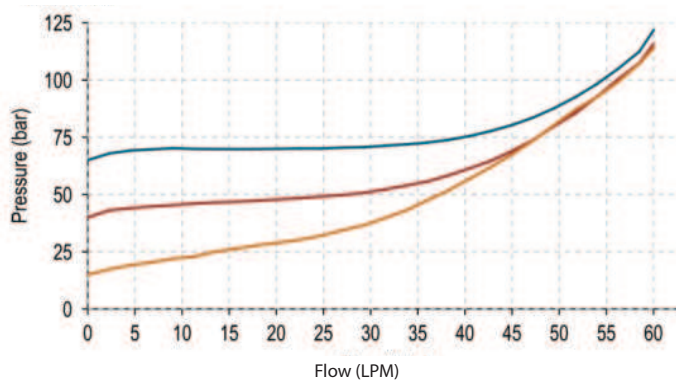

● Spring = B

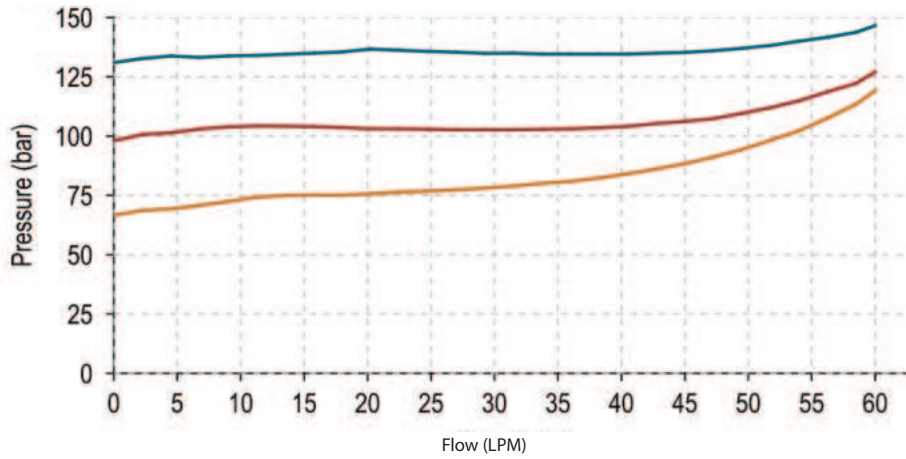

● Spring = G

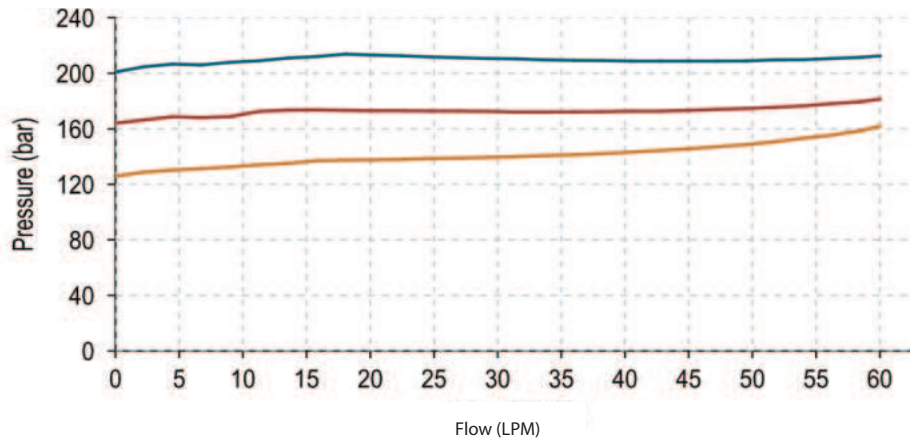

● Spring = V

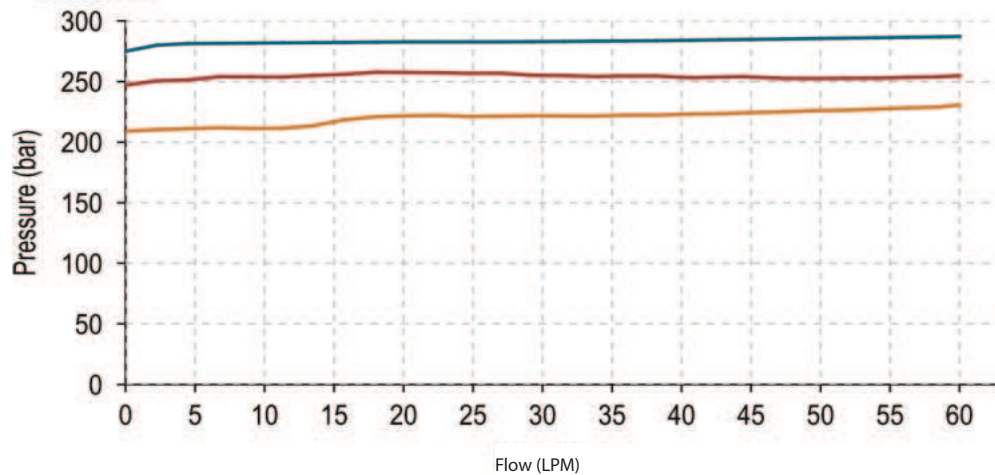

● Spring =W

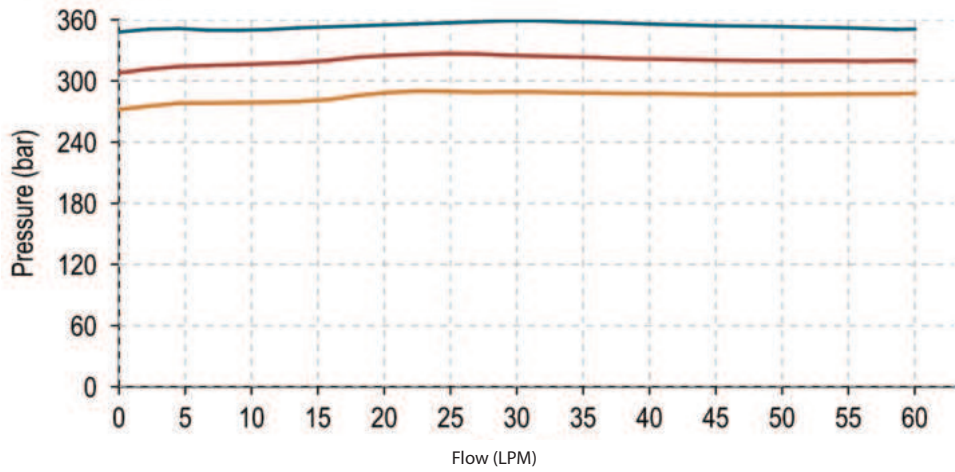

● Spring =R

