



IS.0.M27 Valve Series

METRIC Cartridge - 420 Bar
Direct acting - Poppet type

Description & Operation

A screw-in, direct acting, poppet type check valve. Main use is as a blocking or load-holding device. The IS.0.M27 allows flow passage from port 1 to 2: the cartridge has a fully guided check which is spring-biased closed until sufficient pressure is applied at port 1 to open to 2. The flow is blocked in the opposite direction (2 to 1). Insert type valve: the poppet seals directly against the cavity.

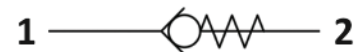
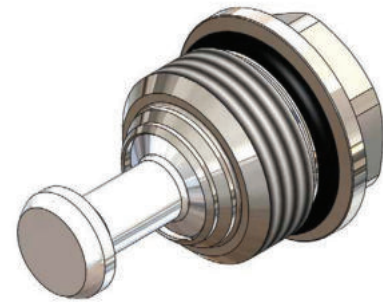

Hydraulic Symbol

Technical Data

Maximum operating pressure	420 Bar
Maximum flow	150 l/min
Maximum internal leakage	0.10 cm ³ / min @ 10 Bar 0.10 cm ³ / min @ 420 Bar
External component treatment	Zn/Fe - standard (96h) Zn/Ni (720h)
O-ring Temperature Range	-30° C to 110° C (standard sealing NBR - BUNA-N)
Oil Temperature Range	-30° C to 110° C
Fluids	Mineral - based or synthetics with lubricating properties
Viscosities	7.4 to 420 cSt
Minimum pull-in voltage	85% of nominal
Filtration	20/18/15 ISO 4406 (maximum filtration admitted)
Orientation	No restrictions
Installation torque	70-80 Nm
Oil testing condition	ISO VG 46 cSt
Seal kit code	SLKT.044
Coining Kit	CK.005
Weight	0.113 kg

Performance Curve

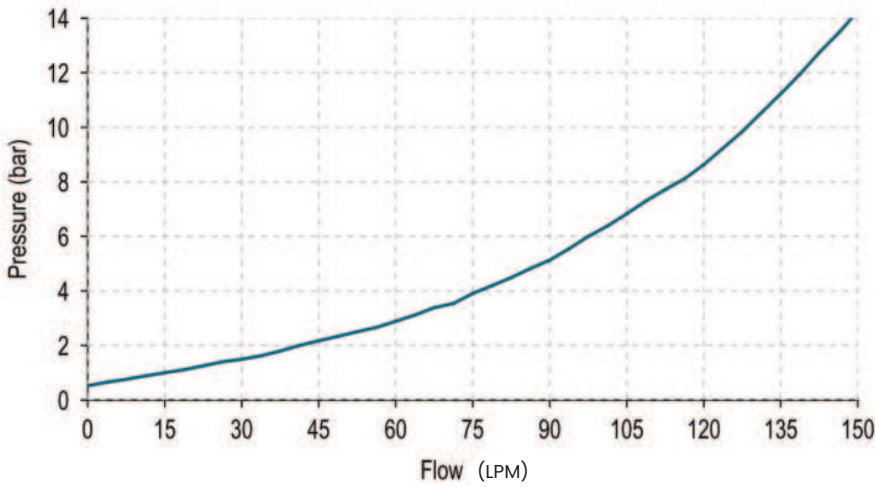

Note:
The performance chart illustrates flow handling capacity for standard bias springs. p/Q curves are recorded at TOil = 40°C and 46 cSt

Dimensional Drawing

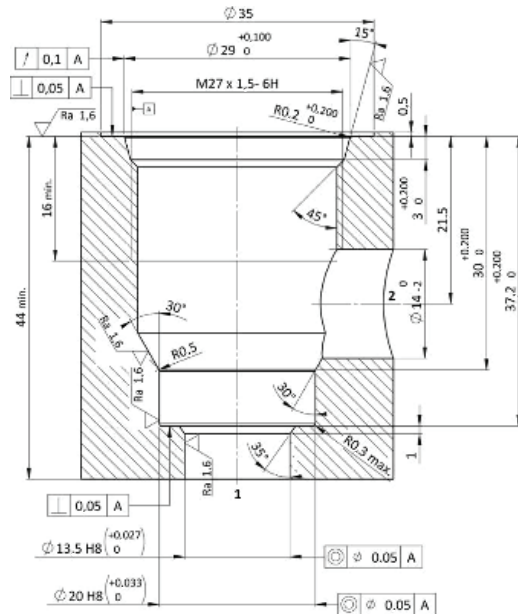
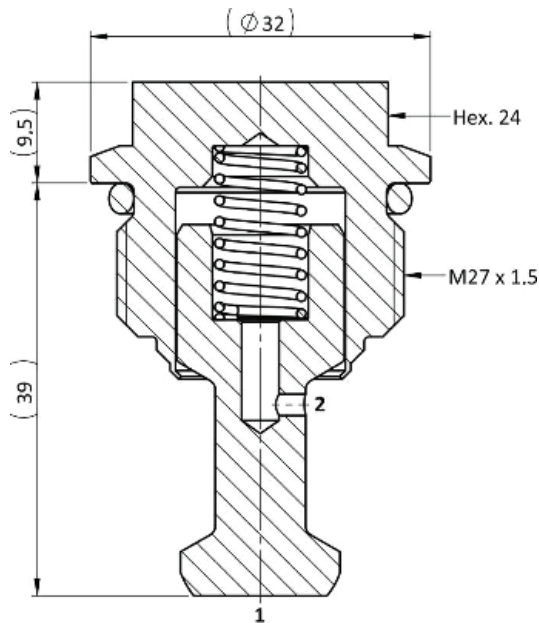

Ordering Code

I S • 0 • M 2 7 • 0 * • 0 0 0

valve basic code

000= standard configuration

Cavity
M27 = METRIC M27 x 1.5

Marking
0 = standard factory marking. customized marking can be done upon request

Bias Spring Options

Spring Model Code	Cracking Pressure (Bar)
N	0.5

CHECK VALVES